



**Dehler**   
**46**

**Dehler**   
**46**

VALUES

# A TRUE DEHLER

**Eine Yacht – wie die Dehler 46 – kann man nur bauen, wenn man durch und durch Segler ist.** Nur wer sein Leben diesem wunderbaren Sport gewidmet hat, bleibt seinen eigenen Werten treu – und entwickelt jede Yacht mit derselben Hingabe, Innovationskraft und Präzision. Wir bei Dehler machen das so seit über 50 Jahren.

**To build a yacht like the Dehler 46, you have to be a sailor through and through.** Only those who dedicate their life to this wonderful sport will always stay true to their values and develop each yacht with equal commitment, innovative power and precision. At Dehler, we have been doing this for more than 50 years.



## VALUES

# PERFECTION IS BASED ON EXPERIENCE

**Ein neues Dehler Modell ist erst vollendet, wenn es nichts mehr zu optimieren gibt.** Bis dahin fließt unsere ganze Erfahrung aus Jahrzehnten Konstruktionsarbeit, tausenden Yachten und kontinuierlichen Innovationen in die Entwicklung mit ein.

**The creating process of a new Dehler model is only completed once there is nothing left to improve.** Up to this point, all the experience we gained from decades of design work, thousands of yachts and continuous innovations are incorporated into the development.

## 25,434 YACHTS

have been delivered by Dehler since 1963 – an experience that results in excellence.

## 859 INNOVATIONS

that made sailing and living on board significantly more enjoyable were invented by Dehler.

## 64 MODELS

in all sizes up to 60 feet were created by our designers and developers.

MORE THAN  
**50 YEARS**

of yacht building have continuously increased the demands we place on ourselves and made us one of the leading sailing boat manufacturers.

## 1 PROMISE

follows from all we achieved until today:  
To build the one Dehler 46 you wish for.



VALUES

# DEHLER 46

## FULL OF IDEAS

### MORE SPEED

- | Maximised sail area
- | judel/vrolijk & co designed performance hull
- | Light-weight construction
- | Competition options available

### PERFECT QUALITY

- | Full sandwich hull
- | Durable & reliable materials installed
- | Hand-laid teak deck with vacuum bonded wood

### HIGHEST SAFETY

- | High righting moment
- | Dehler hull/deck joint
- | Dehler Carbon Cage

### INTELLIGENT FUNCTIONALITY

- | Steering pedestal
- | Mainsheet traveller
- | Dehler Uni Door Concept

### OUTSTANDING DESIGN

- | Distinctive window line
- | Sleek and elegant profile

### BEST RESALE VALUE

- | Made in Germany
- | Timeless elegance
- | Global customer support

### STRONG INNOVATIONS

- | Carbon reinforcement in the bottom structure
- | German Mainsheet System
- | Plotter pods designed for optimum ergonomics
- | Recessed cockpit seats



# OUR VALUES

**In unserem Streben nach der idealen Yacht lassen wir uns von drei klaren Werten leiten.** Diese Werte haben uns einst zu den Pionieren im deutschen GFK-Bootsbau gemacht – und sie stecken noch heute in jeder Dehler, die unsere Werft verlässt.

**Our passion for creating the perfect yacht is based on three clear values.** These values made us a pioneer in German GRP boat building and can be found today in every Dehler leaving our shipyard.



## Value No. 1

### PROCEED WITH SPEED

**Für uns gehört Segelleistung zu den wichtigsten Tugenden einer Yacht.** Warum? Weil es immer wieder begeistert die Kraft zu spüren, mit der der Bug rasant die Wellen durchschneidet. Und um Begeisterung geht es beim Segeln nun einmal. Deshalb haben auch unsere komfortablen Yachten immer Sport-Genie.

**For us, sailing performance is one of a yacht's most important qualities.** Why? Because it is incredible fun to feel the force the bow exerts when cutting through the waves at a terrific pace; and sailing is simply about having fun. That's why our comfortable yachts have always sports in their DNA, too.

## Value No. 2

### SMART PERFECTION

**Eine perfekte Yacht ist schnell, sicher und schön.** Die Ausstattung lässt keine Wünsche offen. Im Design verschmilzt Funktion mit Ästhetik und die Verarbeitung ist makellos bis ins kleinste Detail. Diesen hohen Ansprüchen fühlen wir uns bei Dehler täglich verpflichtet. Wir bauen jede Yacht so, dass Sie beeindruckt sind von den vielen cleveren Ideen. Wenn alle Lösungen ganz einfach aussehen, obwohl es harte Arbeit war, dann ist es „Smart Perfection“.

**A perfect yacht is fast, safe and beautiful.** Its features meet any desire a sailor might ever have. Its design blends functionality with aesthetics, and the workmanship is flawless, right down to the smallest detail. These are the high standards we are committed to, striving to meet them every day. We build each yacht in such a way that you will be impressed by lots of clever ideas. 'Smart Perfection' is when solutions seem really simple although hard work has been put into them.

## Value No. 3

### GERMAN ENGINEERING

**Dehler steht für die Werte, die „Made in Germany“ zu dem Gütesiegel gemacht haben, das es bis heute ist.** Vor allem zählt für uns Gründlichkeit. Präzision in jedem Detail prägt unser Denken und Handeln sowie die Wahl unserer Partner. Dazu gehören vor allem die international renommierten Yacht-Konstrukteure judel/vrolijk & co. Sichtbar wird dies in zeitlosen Formen mit dynamisch-eleganten Linien.

**Dehler justifies values that turned 'Made in Germany' into the seal of approval that it is today.** Thoroughness counts before everything else. Precision in every detail is what shapes the way we think and act as well as who we choose to be our partners. Most notably, the internationally renowned yacht designers judel/vrolijk & co belong to our partners. Timeless shapes with dynamic, elegant lines are testimony to all of this.



DEHLER 46

# CONTENT

## INHALT

### VALUES

2 A TRUE  
DEHLER

4 PERFECTION  
IS BASED ON  
EXPERIENCE

6 DEHLER 46  
FULL OF IDEAS

8 OUR VALUES

### INDIVIDUALITY

12 IT'S UP TO YOU

14 EASY TO SAIL

15 HARD TO BEAT

60 PACKAGES

62 OPTIONS

### EXTERIOR

18 DECK

22 HULL

28 TECHNICAL  
SPECIFICATIONS

30 MATERIALS &  
COLOURS

### INTERIOR

38 SALOON &  
PANTRY

42 MASTER &  
GUEST CABIN

44 CABIN LAYOUTS

46 MATERIALS &  
COLOURS

### TECHNOLOGY

25 CARBON RIG

26 DEHLER  
CODE ZERO

54 DEEPER INSIDE

58 SAFETY CLOUD

## INDIVIDUALITY

# IT'S UP TO YOU

Rumpf in innovativer Vakuum-Infusions-Bauweise, optimierte Lastverteilung durch Dehler Carbon Cage, intelligentes Uni Door Raumbad, Laminatsegel – das sind nur einige der Highlights. Viel Spaß bei der individuellen Gestaltung Ihrer Dehler 46.

Innovative vacuum infused hull, optimized load distribution by Dehler Carbon Cage, intelligent uni door en-suite bathroom solution, laminated sails – these are just some of the highlights offered. Enjoy customising your Dehler 46.



”

*Following the new established design lines, the Dehler 46 offers a well-balanced ratio between cruising comfort and swift performance. The new window line identifies it as a Dehler even from a far distance. The true strength though lies in its versatility. See it as an upgrade from a perfectly equipped cruiser to an outstandingly fast competitor or vice versa. The Dehler 46 is the perfect platform to enjoy every sailing style to the fullest.*

*Torsten Conradi, Managing Director of judel/vrolijk & co*

## INDIVIDUALITY

# EASY TO SAIL

**Höchster Segelkomfort gehört bei einer Dehler zur Gundausrüstung.** Bestes Beispiel: das German Mainsheet System. Die beiden Enden der Großschot werden auf getrennte Winschen gelegt. So haben Sie die Schot auf beiden Cockpitseiten in unmittelbarer Reichweite. Ohne Ihren Steuerstand zu verlassen, behalten Sie volle Kontrolle über das Segel.

**On a Dehler, great sailing comfort is part of the basic equipment.** It comes, for example, with the German Mainsheet System: both ends of the mainsheet are taken to separate winches. Now the line is within immediate reach on each side of the cockpit. You will always maintain full control of the mainsail without leaving the helm.



# HARD TO BEAT

**Ein paar Modifikationen genügen, und schon wird aus dem komfortablen Performance-Cruiser eine reinrassige Regatta-Yacht.** Für kleine und große Crews, für die All-day-Wettfahrt mit Freunden und Steg-Nachbarn, für die Regatta mit internationalem Feld – oder einfach nur für Ihren ganz privaten sportlichen Ehrgeiz. Viel Spaß.

**Just a few modifications and your luxurious performance cruiser will be turned into a pure regatta yacht.** For smaller and bigger crews, for the all-day-races with friends and jetty neighbours – or simply for your very private sporty ambitions. Have fun.





**Dehler**   
**46**

EXTERIOR

# CHARACTER THAT MEETS THE EYE

**Eine Dehler 46 ist unverkennbar.** Sie besticht durch eine einzigartige Persönlichkeit, die mit klaren Linien und einem einfallsreichen Exterieur überzeugt. Eine Yacht mit Klasse und unverfälschtem Charakter.

**A Dehler 46 is unmistakable.** She impresses with a unique personality that stands out with clean lines and an imaginative exterior. A yacht with class and genuine character.





Flush hatches on coach roof.

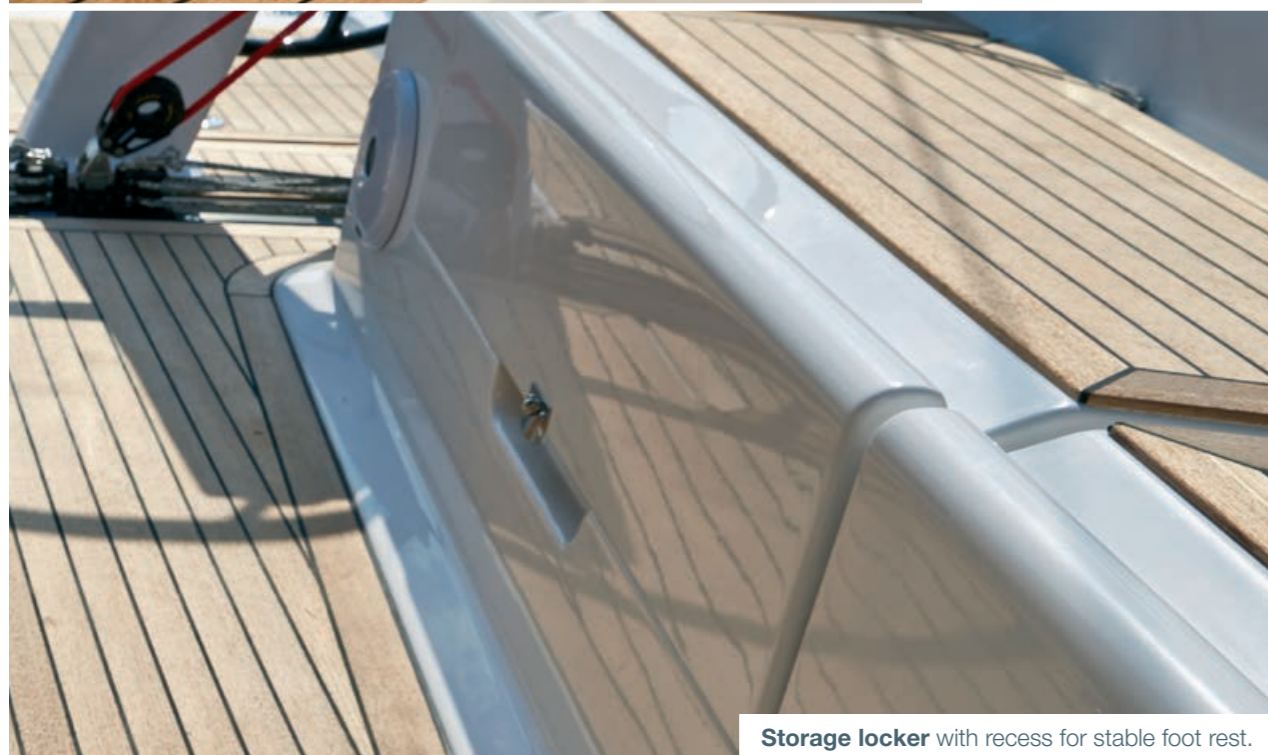

Storage locker with recess for stable foot rest.

## EXTERIOR

# DECK

**Auf den ersten Blick fällt das klare und aufgeräumte Deckslayout ins Auge.** Hier sitzt jeder Handgriff. Die vielen intelligenten Details machen das Segeln so einfach, selbst mit kleiner Crew.

**At first glance, the clear and uncluttered deck layout catches your eye.** Everything is running smoothly. Many intelligent details make sailing so easy, even with a small crew.



The elegant and roomy cockpit provides space for the whole crew.

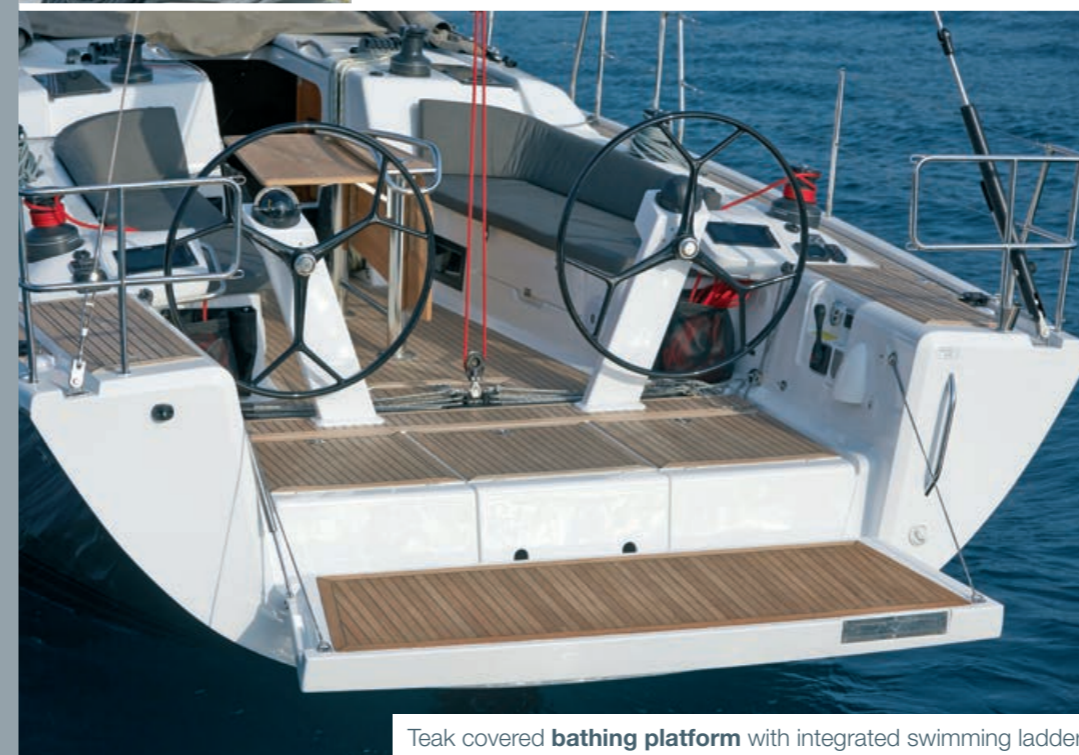

Teak covered bathing platform with integrated swimming ladder.



The mast is keel stepped for better performance.



The new Dehler design is recognised by the dynamic line of the cabin windows, which can all be opened individually. These are additionally emphasised due to the aluminium frame.

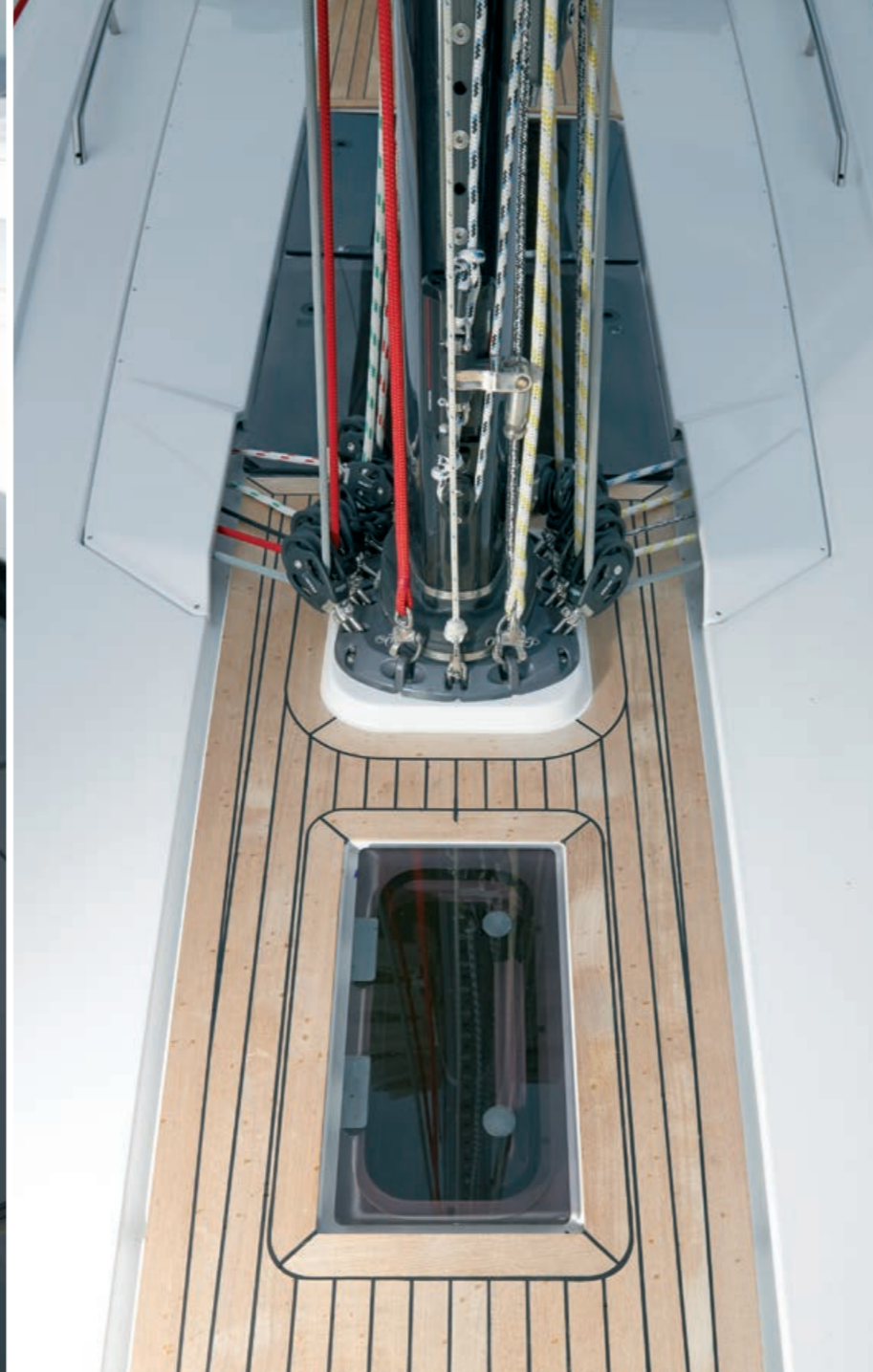

Hidden halyards allow the deck design to be clean-cut.



Full control at helmsman position thanks to the elegant instrument consoles.



Space for the whole crew in the protected cockpit. Removable table and wide passageway.



Being recessed into the floor, the mainsheet traveller allows an ideal trim of the mainsail.



## EXTERIOR

# HULL

**Die innovative Vakuum-Infusions-Technologie** sorgt dafür, dass der 13,95 Meter lange Rumpf aus Osmose-resistentem Vinylesterharz 20 Prozent steifer als bei herkömmlicher Bauweise wird. Der steile Steven verlängert die Wasserlinie und resultiert in einer erhöhten Rumpfgeschwindigkeit. Serienmäßig besitzt die Dehler 46 einen 2,25 Meter langen Kiel, während die sportliche Version mit einem Kiel von 2,58 Meter Länge punktet. Für das Segeln in Flachwasser-Revieren steht optional ein Kiel mit 1,87 Meter Tiefgang zur Auswahl. Alternativ können Sie auch einen 2,48 Meter langen West Coast L-Kiel wählen.

**The innovative vacuum infusion technology** ensures that the 13.95-metre-long hull made of water-resistant vinylester resin is 20 percent more rigid than conventional designs. The steep stem extends the waterline and results in increased hull speed. As standard the Dehler 46 comes with a 2.25-metre-deep keel, while the competition version carries with a keel depth of 2.58 metres. Optional for sailing in areas with shallow waters is a keel with 1.87 metres draught. We also provide a 2.48-metre-deep going West Coast L-Keel.



Upwind, downwind or reaching at maximum speed due to the **versatile hull design**.

## TECHNICAL RIG SPECIFICATIONS

	STANDARD
Weight	485 kg / 1,069 lbs
Shrouds	1x19
Total Sail Area	114 m <sup>2</sup> / 1,228 sq ft
Backstay	one-sided
Spreader	Alu
Boom	Alu
Boom Vang	Alu
Main Sail Sliders	Selden
I	18.10 m / 59'5"
J	5.29 m / 17'4"
P	17.60 m / 57'9"
E	6.25 m / 20'6"

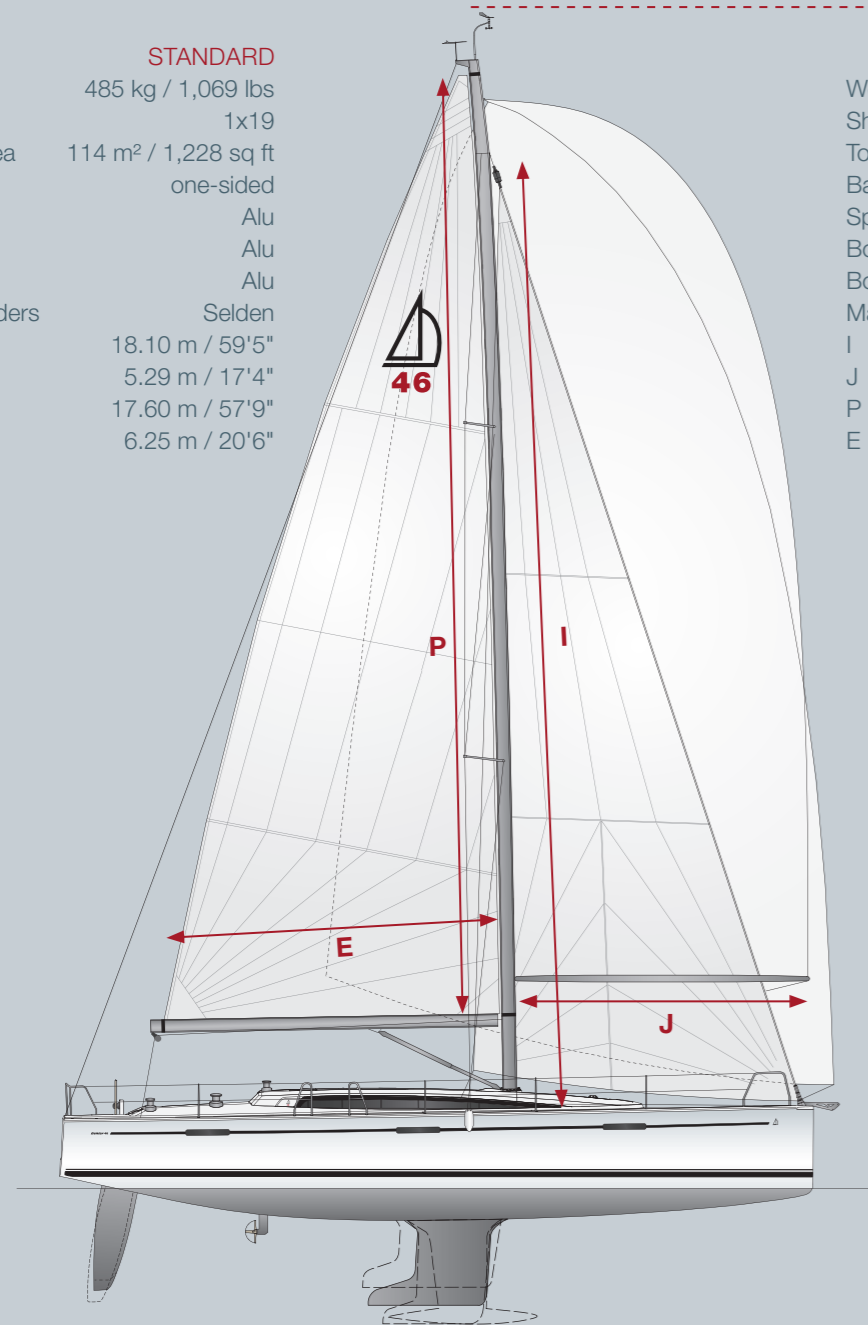

	CARBON RIG
Weight	365 kg / 805 lbs
Shrouds	Rod Rig
Total Sail Area	128 m <sup>2</sup> / 1,302 sq ft
Backstay	double-sided
Spreader	Carbon
Boom	Carbon
Boom Vang	Carbon
Main Sail Sliders	Antal
I	18.90 m / 62'0"
J	5.29 m / 17'4"
P	17.68 m / 58'0"
E	6.55 m / 21'6"



## EXTERIOR

# CARBON RIG

Unser Rigg aus dem Hightech-Werkstoff Karbon bringt entscheidende Vorteile: Der Mast ist länger, leichter und steifer als der Standard-Alu-Mast, bietet eine größere Segelfläche – und damit ein Mehr an Segelleistung bei leichtem Wind und bei Seegang.

Our rig made of the high-tech material carbon provides decisive advantages: The mast is longer, lighter and stiffer than the standard alu mast. It enlarges the sail area, which increases the sailing performance in rough seas and light winds.

## BOOST YOUR SAIL PERFORMANCE BY 28 S/NM

When equipped with HPM sails and carbon rig, competition rudder and deep keel, your Dehler 46 can sail significantly faster:

ALU RIG		CARBON RIG	
at 16 kn true wind		at 16 kn true wind	
41.1°	7.6 kn	39.1°	7.78 kn
60°	8.71 kn	60°	8.84 kn
90°	9.27 kn	90°	9.61 kn
120°	9.76 kn	120°	10.00 kn
135°	9.23 kn	135°	9.39 kn

As a result the yacht is approx. **28 s/nm faster**, achieving an ORC value of **GPH 550 s/nm**.

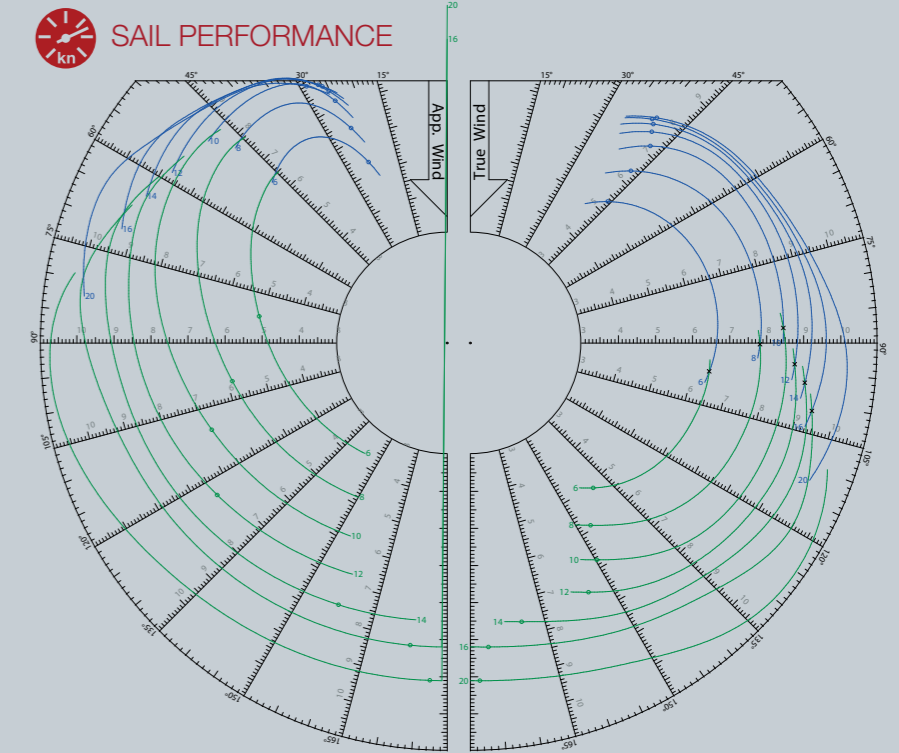



NEW!

# DEHLER CODE ZERO

Das neue Dehler **CODE ZERO** besitzt die perfekte Segelgröße zwischen Genua und Gennaker und hat den größten Windeinsatzbereich seiner Klasse. Das heißt: Vom Am-Wind-Kurs bis zum tiefen Raumkurs bringt das CODE ZERO Ihre Dehler auf Geschwindigkeit.

Dabei ist es ein voll einhandaugliches Segel. Es wird aus dem speziell entwickelten Sailbag vom Deck gesetzt. Mit zwei Klicks wird es am Ankerbeschlag und Gennakerfall befestigt und kann eingerollt als zweites Vorstag im Hafen gesetzt bleiben. Gefahren wird das Dehler CODE ZERO mit den Gennakerschoten über eine beliebige Winsch im Cockpit.

The new Dehler **CODE ZERO** is the perfect intermediate size between genoa and gennaker, offering the largest wind range in its class. That means, the CODE ZERO speeds up your Dehler, no matter if you are sailing a close reach or broad reach course.

Fully optimised for single-handed sailing, it is set out of the specially designed sailbag at deck level. Attaching it to the anchor bracket and gennaker halyard takes two simple clicks. The rolled-up sail can remain set as second forestay in the marina. It is operated with the gennaker sheets using any winch in the cockpit.



Dehler CODE ZERO:  
Standard: 84.4 m<sup>2</sup>  
Competition: 98.0 m<sup>2</sup>

— UV-protected

— integrated torsion cable and endless furling system

## PERFORMANCE SAILS

Layout / Cloth



Accessories

2 reefs, 4/4 battens

Dehler 46

Sail Size 114.10 m<sup>2</sup>

Dehler 46 Carbon Rig

Sail Size 121.00 m<sup>2</sup>

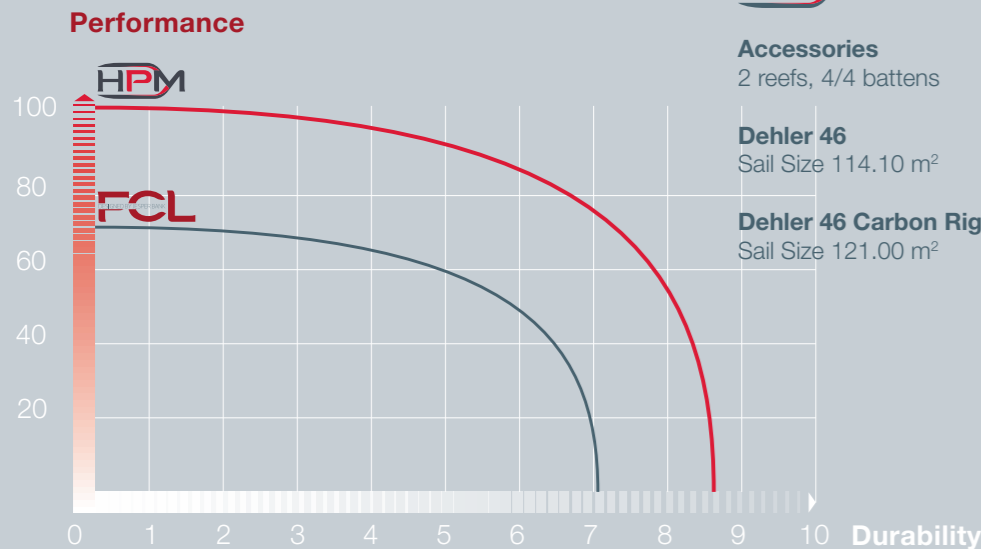

## DEHLER CODE ZERO

- | Up to 98.0 m<sup>2</sup> sail area, for wind speeds starting at 5 kn
- | Made of CZ laminate with trioptimal cut – a very lightweight black material containing Twaron high-performance fibres and black Technora X – Ply
- | Quickly fixed with just two clicks and rolled out
- | High-grade furling system and special furling cable included
- | Specially developed weatherproof sailbag

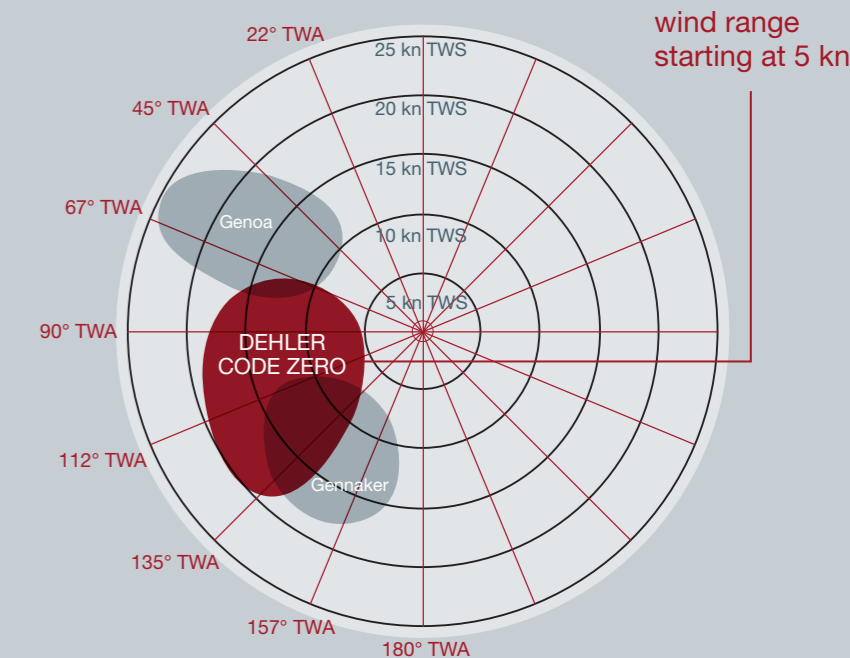

## EXTERIOR

# TECHNICAL SPECIFICATIONS

Mit unseren vielfältigen Ausstattungsoptionen können Sie Ihre Dehler auf Ihr Segelrevier und Ihre Art zu segeln abstimmen. Wählen Sie aus vier Kielarten – von der Flachwasser- bis zur Performance-Version mit extrem tiefem Schwerpunkt. Wünschen Sie es noch sportlicher, nehmen Sie das Carbon- anstelle des Aluminium-Riggs. Für die optimale Geschwindigkeit bei tieferen Kursen bietet Ihnen die Dehler 46 die Möglichkeit, gleich drei verschiedene Segel einzusetzen.

Thanks to our diverse range of configuration options, you can perfectly adapt your Dehler to your yachting waters and manner of sailing. Choose from four keel types: from shallow water to a performance version with an extremely low centre of gravity. If you want it even sportier, opt for the carbon rig instead of aluminium. When it comes to achieving optimal speeds with downwind courses, your Dehler 46 lets you select from three different sails.

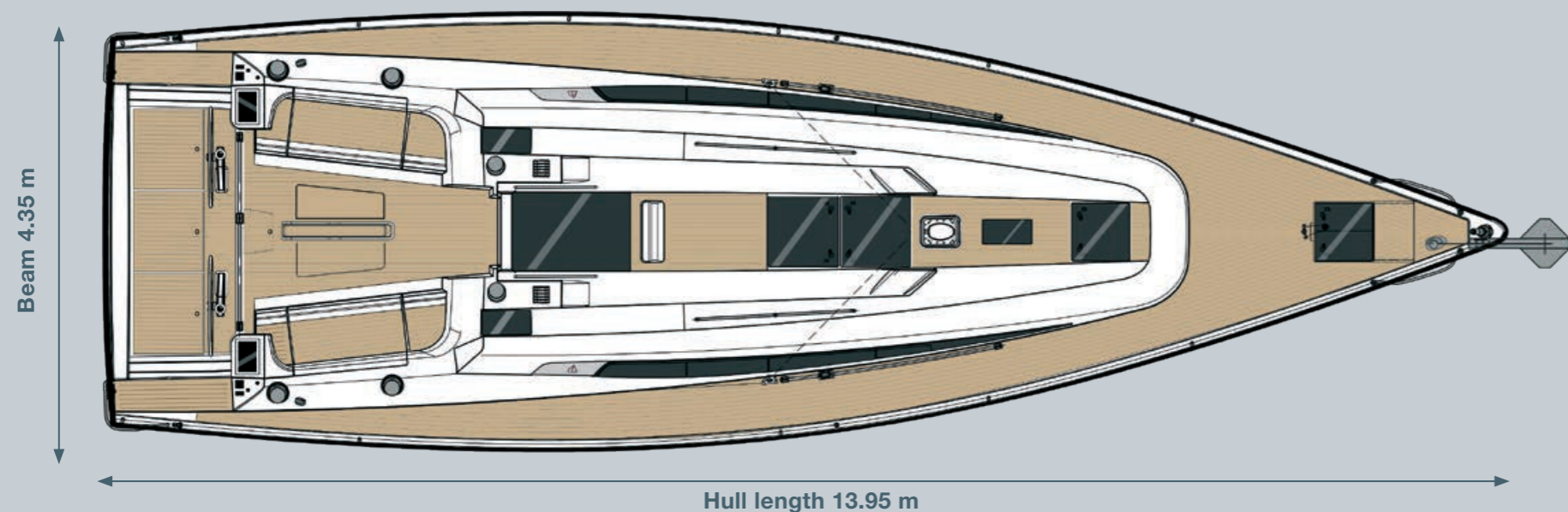

## TECHNICAL SPECIFICATIONS

<b>HULL</b>	
LOA	14.76 m / 48'5"
Hull Length	13.95 m / 45'9"
LWL	12.90 m / 42'4"
Beam	4.35 m / 14'3"

<b>DRAUGHT</b>	
Standard	2.25 m / 7'5"
Competition	2.58 m / 8'6"
Shallow	1.87 m / 6'2"
West Coast	2.48 m / 8'2"

<b>DISPLACEMENT</b>	
Standard	11.50 t / 25,353 lbs
Competition	11.20 t / 24,691 lbs
Shallow	11.90 t / 26,235 lbs
West Coast	11.40 t / 25,132 lbs

<b>BALLAST</b>	
Standard	3.50 t / 7,716 lbs
Competition	3.15 t / 6,944 lbs
Shallow	3.85 t / 8,488 lbs
West Coast	3.35 t / 7,385 lbs

<b>ENGINE</b>	
Engine	51.0 PS / hp
Engine Option	75.0 PS / hp

<b>TANKS</b>	
Fresh Water	450 l / 118.88 gal
Fuel Tank	210 l / 55.48 gal

**HULL DESIGN**  
judel/vroljik & co

**INTERIOR DESIGN**  
Dehler

**CE CERTIFICATE**  
The Dehler 46 is built according to CE Certification, Class A

<b>RIG</b>	
Mast length above WL	
Standard	21.20 m / 69'7"
Competition	22.20 m / 72'8"

<b>MAINSAIL</b>	
Standard	Competition
64.40 m <sup>2</sup> / 693 sq ft	70.00 m <sup>2</sup> / 754 sq ft

<b>FURLING JIB</b>	
Standard (106 %)	Competition (106 %)
49.70 m <sup>2</sup> / 544 sq ft	51.00 m <sup>2</sup> / 549 sq ft

Standard	Competition
I 18.10 m / 59'5"	I 18.90 m / 62'0"
J 5.29 m / 17'4"	J 5.29 m / 17'4"
P 17.60 m / 57'9"	P 17.68 m / 58'0"
E 6.25 m / 20'6"	E 6.55 m / 21'6"

<b>TOTAL SAIL AREA</b>	
Standard	Competition
114.10 m <sup>2</sup> / 1,228 sq ft	121.00 m <sup>2</sup> / 1,302 sq ft



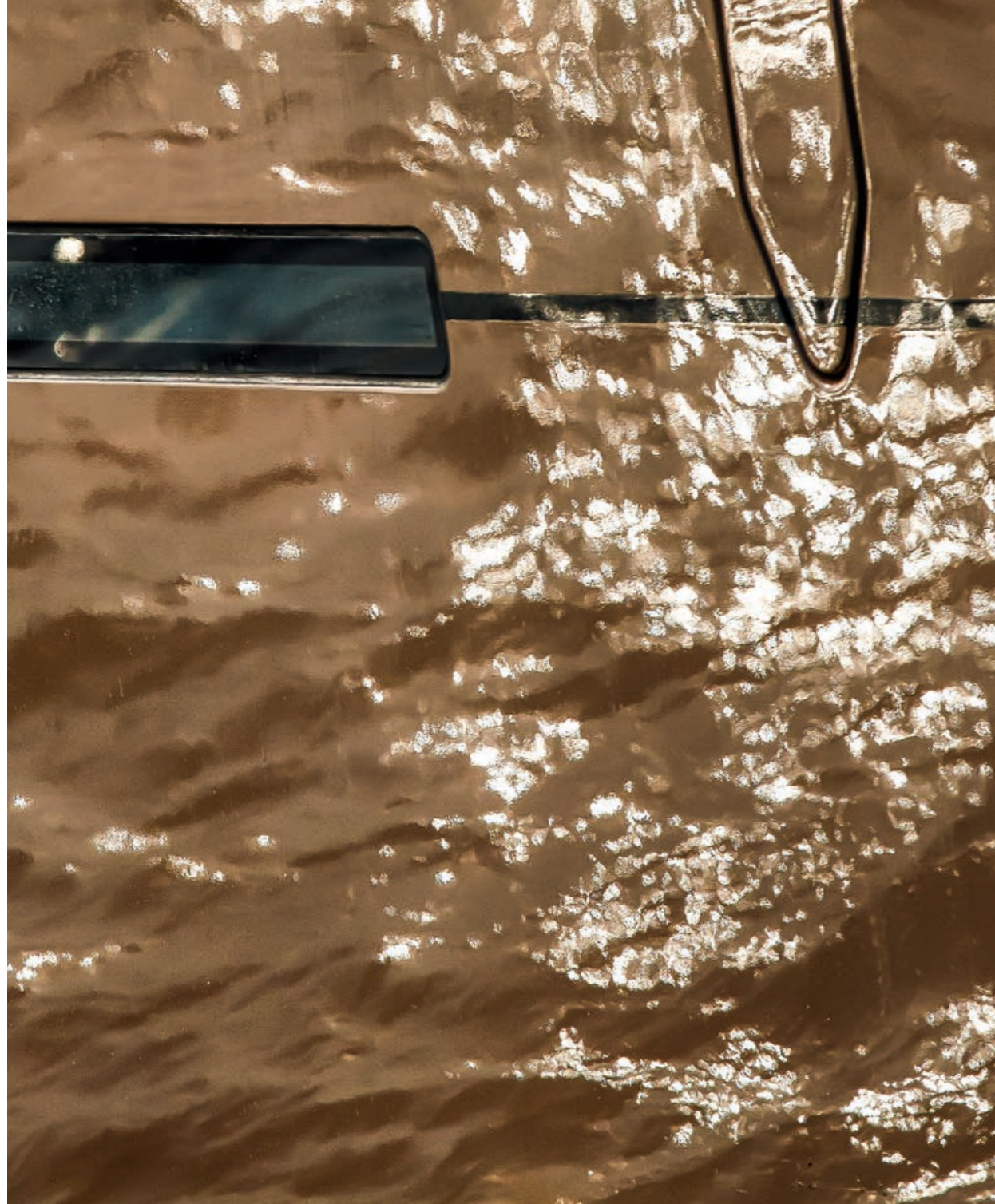

## EXTERIOR

# MATERIALS & COLOURS

### Die Farbe des Rumpfes, der Stil des Teak-Decks:

Erst mit der Gestaltung der Oberflächen verleihen Sie dem Exterieur seinen letzten Schliff.

### The colour of the hull, the style of the teak deck:

It is your personal surface design that applies the finishing touches to the exterior.

## EXTERIOR | GELCOAT HULL, WATERLINE & COVELINE

## EXTERIOR | PAINTED HULL, WATERLINE & COVELINE

The hull, waterline & coveline can be painted in almost every colour (metallic/non metallic) according to the Alexseal Yacht Coatings Selection.

### STANDARD

signal white RAL 9003

dark blue RAL 5004

### OPTIONS

grey RAL 7040

signal white RAL 9003

grey RAL 7040

dark blue RAL 5004

### OPTIONS

oyster white T 9128

flag blue T 5153

palma blue M 5922 (metallic)

off white T 9130

flag blue T 5153

dark grey T 7156



## EXTERIOR | COVERS & UPHOLSTERY

### Maindrop, Sprayhood, Steering Wheel Cover, Cockpit Table Cover

#### OPTIONS

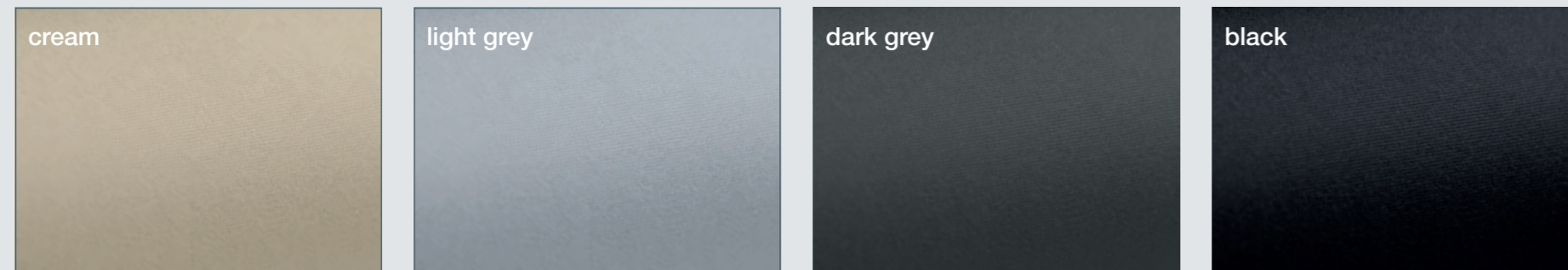

### Cockpit Cushions

#### OPTIONS

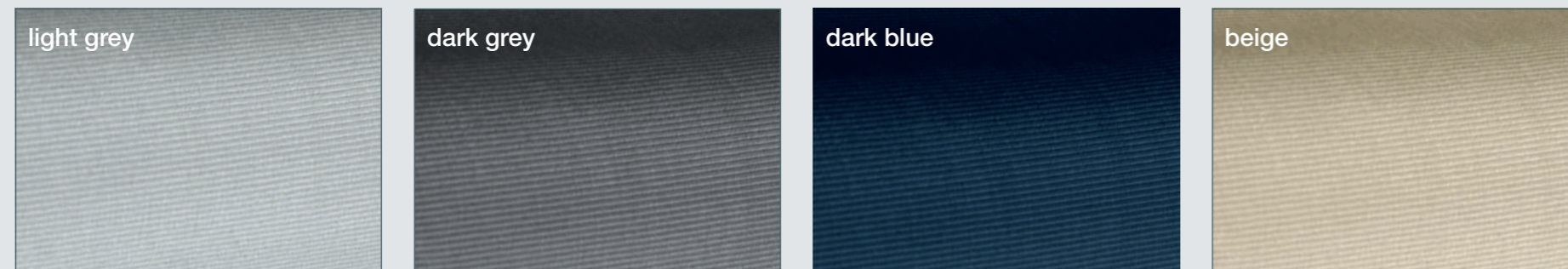

## EXTERIOR | NATURAL TEAK & SYNTHETIC TEAK

### NATURAL TEAK OPTION

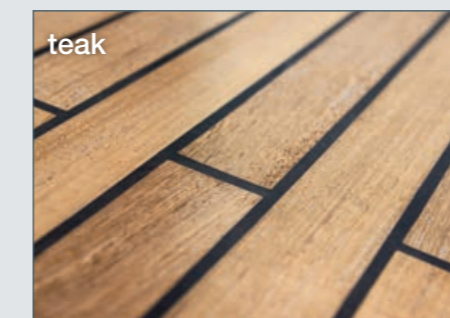

### SYNTHETIC TEAK OPTIONS

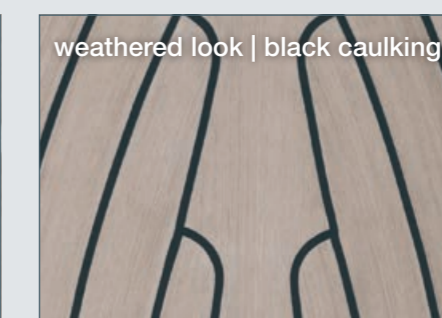
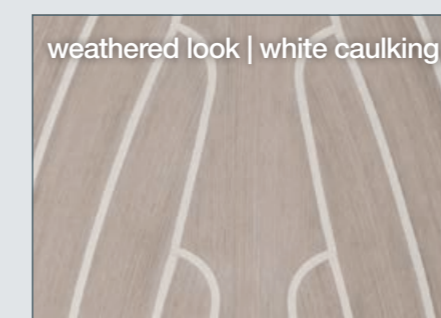
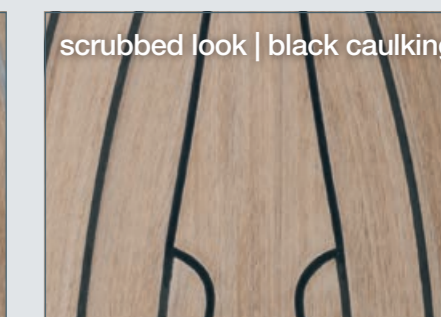
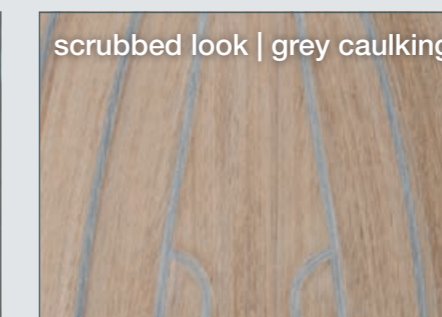
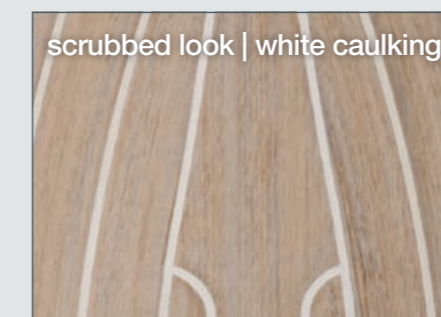
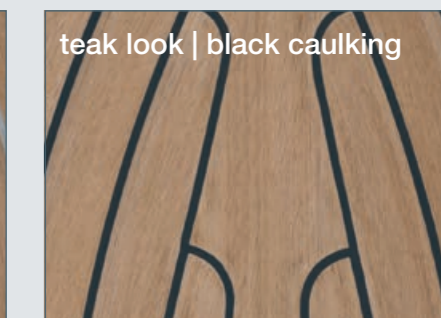
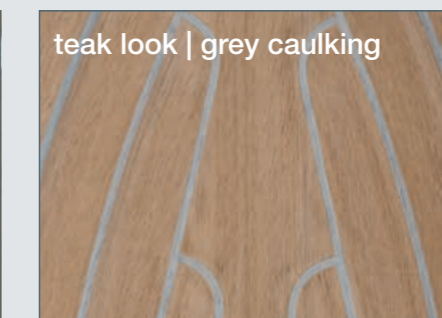



**Dehler**   
**46**

INTERIOR

# DESIGNED TO MAKE YOU FEEL AT HOME

**Machen Sie es sich bequem.** Gestalten Sie den harmonischen Innenraum mit seinen elegant fließenden Formen nach Ihren Wünschen.

**Make yourself comfortable.** Style the harmonious and elegantly shaped interior according to your preferences.



A modern interior design creating an outstanding and cosy atmosphere.



Full control at the generous **navigation area**.



Lowering the saloon table transforms the U-shaped seating into a **lounge area**.

## INTERIOR

# SALOON & PANTRY

**Der zentrale Bereich im Inneren** bietet zahlreiche bemerkenswerte Lösungen zur optimalen Raumnutzung. So lassen sich zum Beispiel die Salonschränke mit ihren ungewöhnlichen Radien praktischerweise nach oben öffnen.

**The central area of the interior** provides many remarkable ways of using space efficiently. For example, the saloon cabinets with their unusual radius open upwards in a practical fashion.



**Spacious galley** where everything is in the right place.



Integrated 130 l fridge accessible from above and below.



Central control panels for lighting and air condition.



Master cabin with **en suite head** and large wardrobes.



**Aft cabin** on starboard.

## INTERIOR

# MASTER & GUEST CABIN

In der **Standard-Version** verfügt die Dehler 46 über eine Eignerkabine mit eigener Nasszelle, eine geräumige Achterkabine steuerbord und einen grossen, begehbaren Stauraum backbord mit einer Einzelkoje, in der zum Beispiel Segellast oder sonstige Bordausrüstung untergebracht werden kann. An dessen Stelle können Sie aber auch eine **zweite Achterkabine wählen**.

The **standard Dehler 46** has a master cabin with head, a spacious aft cabin starboard and a large accessible stowage on portside including a bunk berth which can be used for board equipment or as a sail locker. However, you can also **choose to have a second aft cabin** at this place.



Comfortable master cabin with large **island double berth** and lots of natural light.



Beautiful designed head with separate shower and **Dehler Uni Door Concept**.

## INTERIOR

# CABIN LAYOUTS

**Darauf sind wir stolz:** Das Dehler Uni Door Concept, das Ihnen stets die Wahl zwischen zwei Raum-Layouts lässt. Der Clou dabei ist eine Tür für zwei Rahmen. Schwingt die Tür zur einen Seite, entsteht ein geräumiges Badezimmer, das vom Salon getrennt ist. Schwingt sie zur anderen, verschließt sie stattdessen den Raum mit Dusche und WC. Gleichzeitig gibt sie den Durchgang vom Waschbereich zum Salon frei, was ein besonders großzügiges Raumgefühl schafft.

**We are proud of** our Dehler Uni Door Concept which always gives you a choice between two room layouts. Its key feature is having one door for two frames. The door swings open one way onto a roomy bathroom that is separate from the saloon. When the door swings the other way, it closes the shower and toilet room instead. The hallway from the wash area to the saloon is free at the same time, making the room feel very spacious.

### DEHLER UNI DOOR CONCEPT

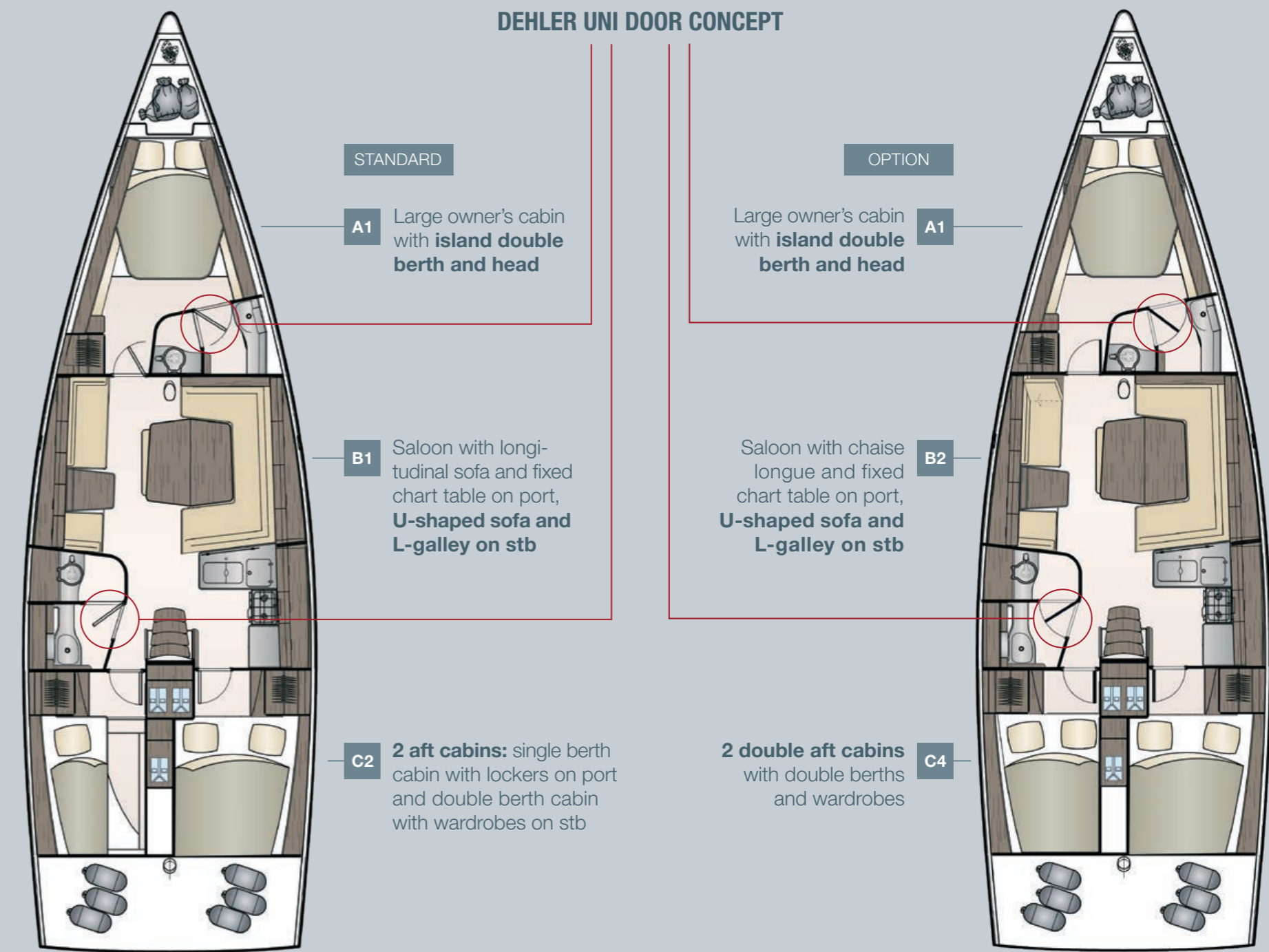



INTERIOR

# MATERIALS & COLOURS

**Selbstverständlich bieten wir Ihnen auch Gestaltungs-Varianten** für die Fußböden, das Holz der Möbel, die Arbeitsplatte in der Pantry und für die Polster. Gestalten Sie die Dehler 46 nach Ihrem Geschmack.

**It goes without saying that we also offer you a variety of designs** for the floorings, furniture wood, worktop in the galley and for the upholstery. Design the Dehler 46 to your own preferences.

## INTERIOR | UPHOLSTERY BALTIC

**Mix and match as you wish.**

All upholstery can be matched with the following piping colours: gold, silver, red, blue and black.

STANDARD

cream / gold piping



cream / blue piping



cream / red piping



cream / black piping



cream / silver piping





## INTERIOR | UPHOLSTERY ARCTIC

Mix and match as you wish.

All upholstery can be matched with the following piping colours: blue, red, black, silver and gold.

### OPTIONS

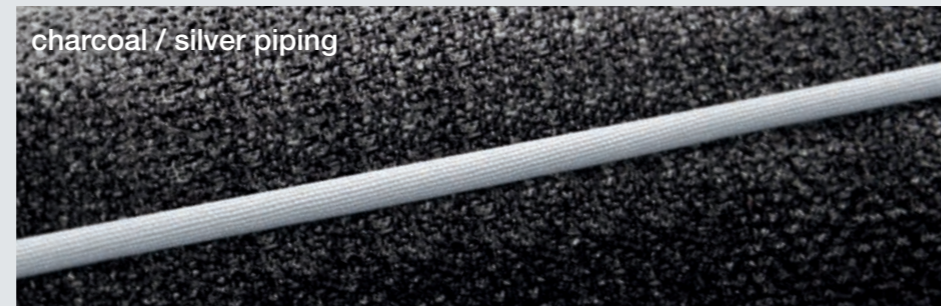

## INTERIOR | UPHOLSTERY PACIFIC

Mix and match as you wish.

All upholstery can be matched with the following piping colours: blue, red, black, silver and gold.

### OPTIONS

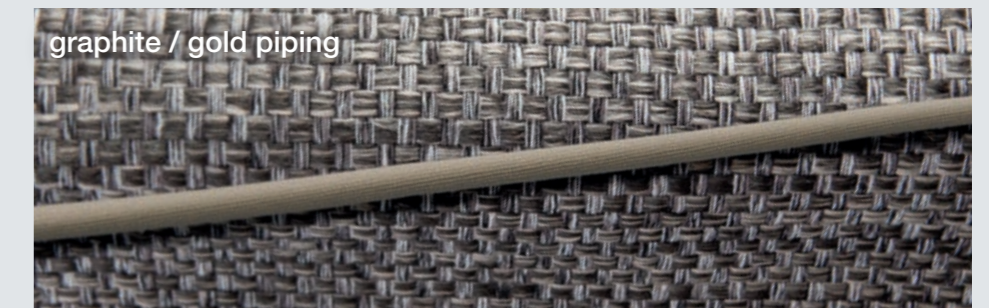
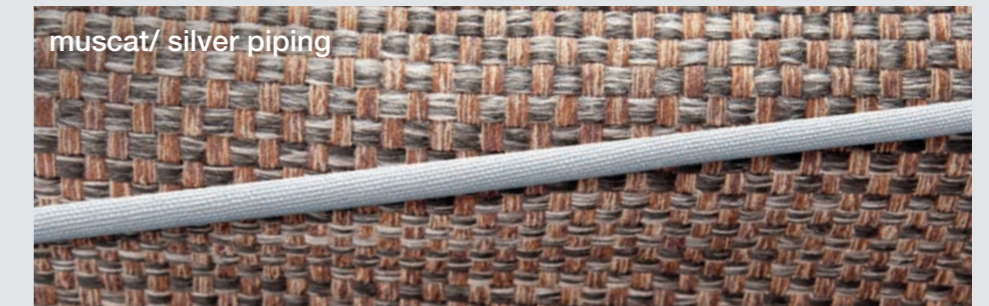

# INTERIOR | UPHOLSTERY ADRIATIC LEATHER

Mix and match as you wish.

All upholstery can be matched with the following piping colours: blue, red, black, silver and gold.

## OPTIONS

ivory / blue piping



clay / red piping



mud / black piping



chocolate / silver piping

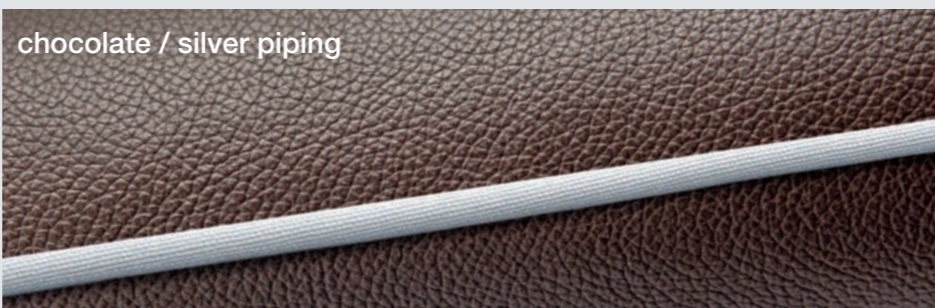

basalt / gold piping



# INTERIOR | SURFACES

## Worktop Galley

### STANDARD

white

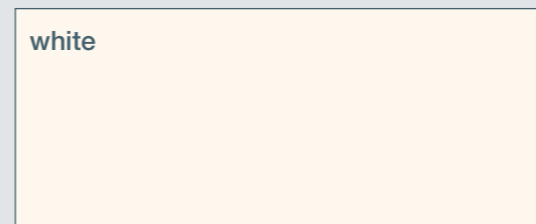

### OPTIONS

black

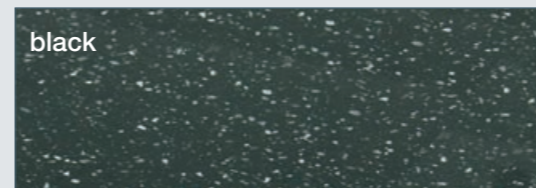

## Furniture Wood

### STANDARD

mahogany

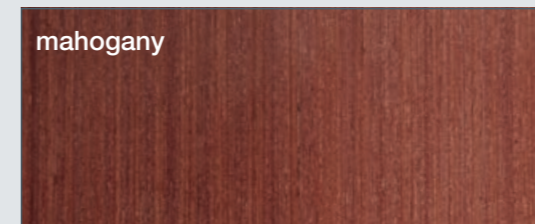

### OPTIONS

teak

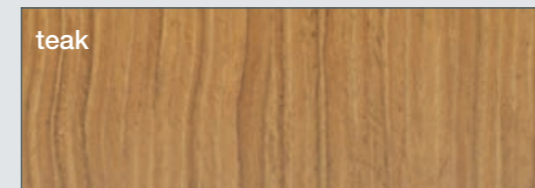

oak

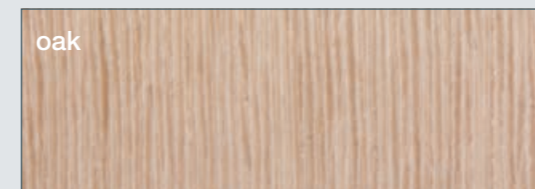

## Floorboards

### STANDARD

australian acacia

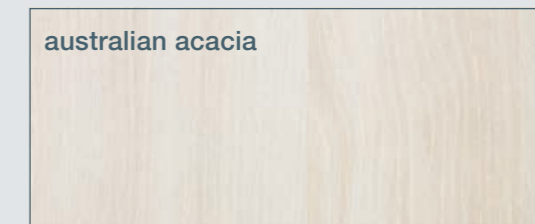

### OPTIONS

noce nero

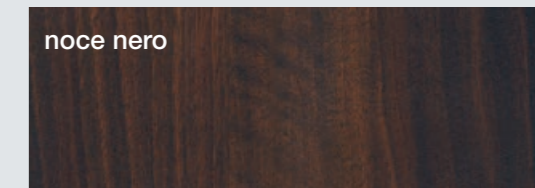

classic stripes

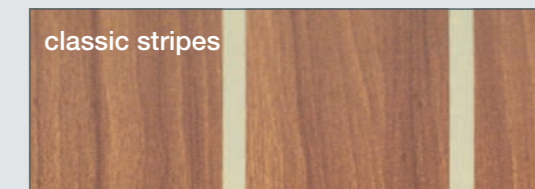

piave oak

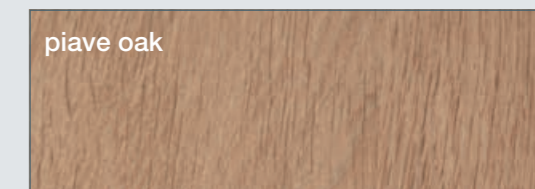



## TECHNOLOGY

# DEEPER INSIDE

Die Dehler 46 ist durchdacht und perfektioniert bis ins letzte Detail. Es wird mit der führenden 3D-Software CATIA entworfen, die auch im Flugzeugbau zum Einsatz kommt. Bestens geschulte Ingenieure gehen in einer virtuellen Yacht ans Werk: Sie teilen Räume intelligent auf, verleihen den Einbauten ausgefallene Formen, erfinden neue Technik – und verwandeln damit die Gesetze der Physik in ein herausragendes Segel-Erlebnis.

The Dehler 46 is well thought-out and perfected down to the last detail. It is designed with the leading 3D software CATIA, which is also used for aircraft development. Working in a virtual yacht, the most qualified engineers divide spaces in a smart way, create extraordinary furniture shapes, invent new techniques – and doing so, they turn the laws of physics into an unrivalled sailing experience.

## 3D CONSTRUCTION

THREE-DIMENSIONAL THINKING CREATES SPACE

### VACUUM INFUSED HULL

Extremely strong and stiff. Due to vacuum vinylester infusion technology, the Dehler 46 comes with an even stiffer hull than her predecessors. A stiff hull is the key to performance! Furthermore, osmosis is a thing of the past.

### DEHLER UNI DOOR CONCEPT

The Dehler Uni Door Concept allows the use of two cabins at the same time. The door is hinged in a position that will either separate the head from the bathroom or close to the adjacent cabin to extend the space of the bath. Smart perfection!

### HULL WINDOWS

- Flush mounted reducing drag when sailing
- More natural light inside the boat

### DOUBLE WHEEL STEERING

- Optimum view and control despite a wide transom
- Helmsman operates from windward rail
- Direct feedback on heeling pressure
- Comfortable and more efficient helming of the boat
- Increased cockpit space
- Perfect view on instruments

### CARBON RIG

- Reduced weight in comparison with common aluminium
- Increased righting moment
- Less keel weight
- Less overall weight

### BOW SPRIT

- Increases sailing performance with asymmetrical headsails
- Allows for increased gennaker surfaces thus increasing downwind performance
- Easier gybing due to increased space between sail and forestay
- Allows for headsails such as CODE ZERO

### UNDER DECK FURLER

- Clew can be attached directly above deck as with common non furling head stays
- Reduced gap between deck and sail
- No loss of pressure
- Maximum use of sail area
- Easy handling with small crew
- Fast reduction of sail area

### BOW THRUSTER

- Better maneuverability in narrow harbours
- No loss in speed due to retractability of thruster into the hull
- Hull becomes a sealed surface when retracted

### MAX BEAM SHROUDS

- High rigidity and stability
- Loads are directly distributed into hull structure
- No loss of tension or hull torsion hence
- Increased performance
- Increased rig performance
- Wider spreaders result in a stiffer rig

### DIESEL TANK

- Optimum weight distribution due to central installation in transom
- Low centre of gravity increasing the righting moment
- Internal splash wall
- Prevents fuel flow being cut off to engine during high heeling angles thus increasing security

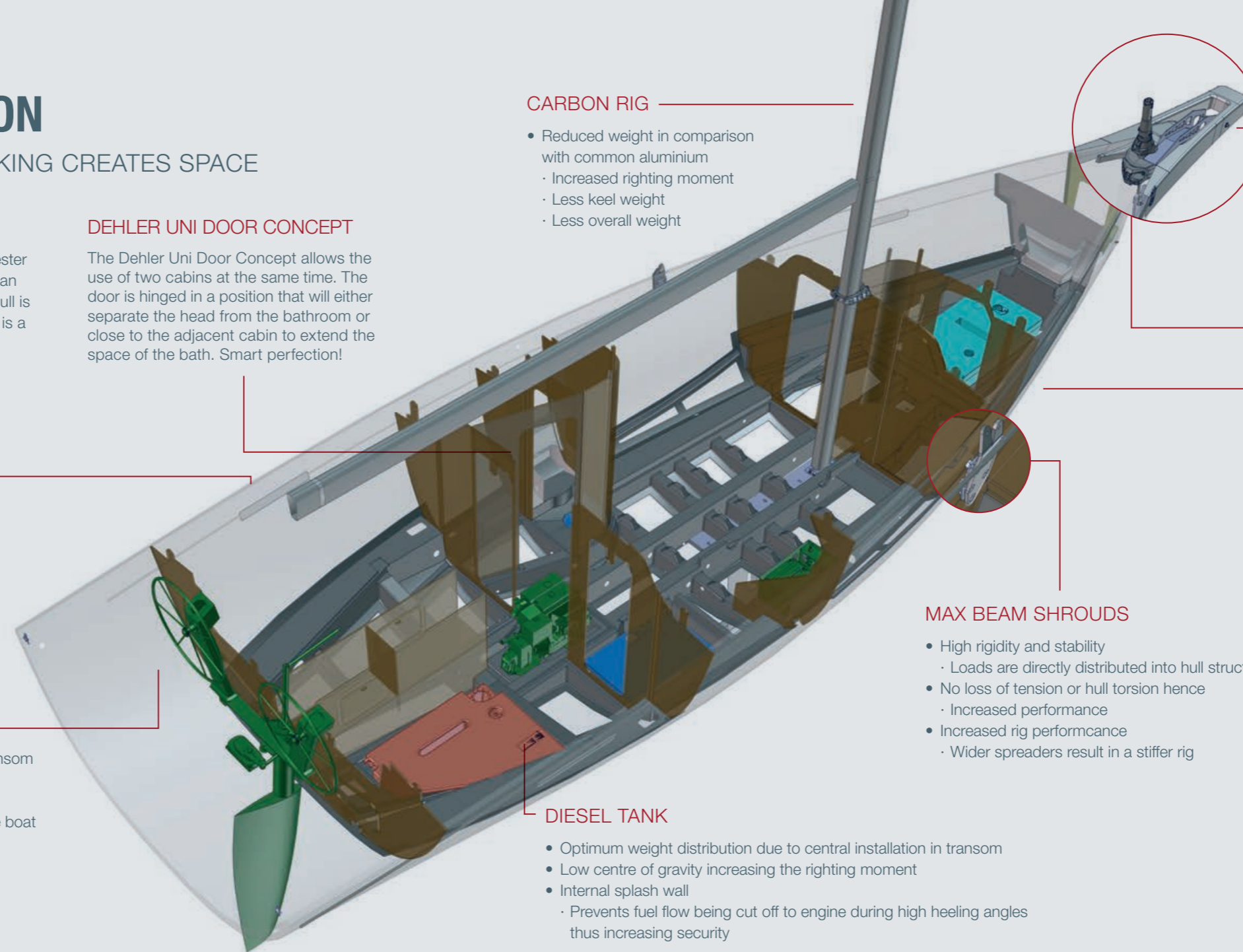

## HIGH-PRECISION MILLING

### A PERFECT YACHT BEGINS WITH A PERFECT SHAPE

Building the mould marks a crucial step when creating a new Dehler. So we focus – as we do at any stage of the manufacturing process – on leading-edge technologies and use computer driven milling systems.

- Hulls and superstructures are cut by a 20-metre-long MAKA CNC milling machine. It creates forms that are perfectly symmetrical and remarkably consistent.
- To generate smaller shapes like our ergonomic plotter pods, Dehler uses a KUKA milling robot. It works with an accuracy of 0.4 millimetres and fits perfectly with our idea of quality.



## KEEL TYPES

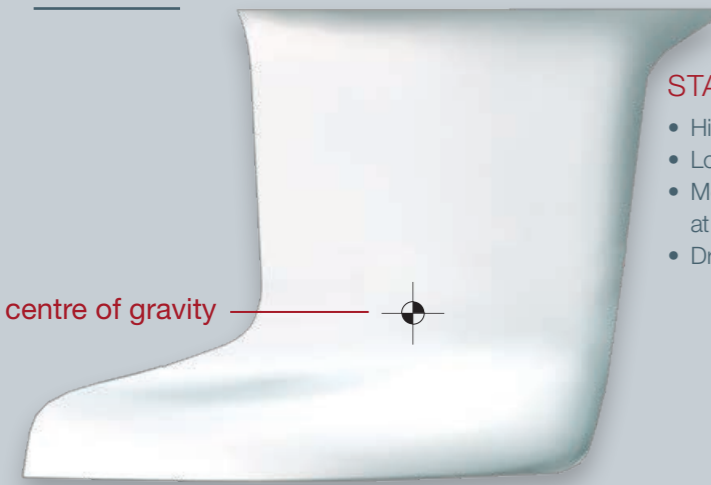

### STANDARD-KEEL

- High-performance deep fin keel
- Low centre of gravity
- Most of the weight is concentrated at the lowest point below the waterline
- Draught 2.25 m, Weight 3,500 kg



### COMPETITION-KEEL

- A hybrid construction comprising a cast iron fin with a lead bulb
- Extremely low centre of gravity, leading to highest possible righting moment
- Narrow fin for reduced drag and higher speed
- Bulb shape achieves optimum hydrodynamics
- Perfect ballast distribution for optimal trim in water Draught 2.58 m, Weight 3,150 kg

lead bulb

## DEHLER CARBON CAGE

A rigid floor structure is the secret in strong and well performing hulls. Being the backbone of the yacht, it directly affects the sailing performance. That is why the Dehler Carbon Cage comes as standard with the Dehler 46.

### HOW IT WORKS

The floor structure is reinforced with carbon fibre at thoughtfully selected points.

### LESS TORSION

The torsion of hull is minimised under high rig loads and in high seas, so it better withstands the forces of water and wind.

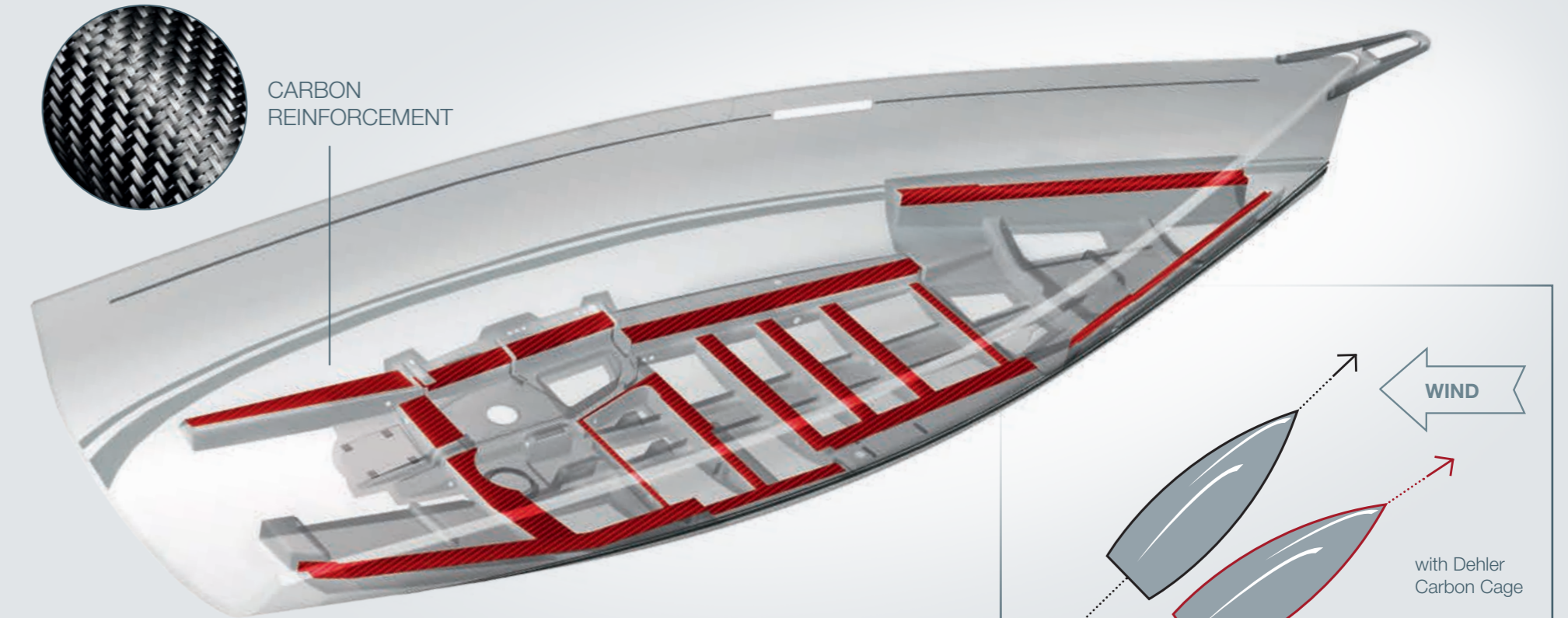

### A NEW LEVEL OF STABILITY

The rigidity of the mast base is increased by 50%; the inner grid is 25% stronger.

### HIGHER LONGEVITY

A hull less stressed lasts longer and extends the life span of your yacht.

### CLOSER TO THE WIND

The Dehler Carbon Cage benefits not only ambitious sailors, it also increases the general sailing fun onboard.

## TECHNOLOGY

# MY DEHLER SAFETY CLOUD

### YOUR ENTIRE YACHT IN YOUR HAND

Alle sprechen von der digitalen Zukunft, doch Dehler setzt sie um – mit dem ersten cloudbasierten Telematiksystem für Serien-Segelyachten. Per Mobile App oder über die owner's area auf [www.dehler.com](http://www.dehler.com) greifen Sie live auf alle relevanten technischen Daten und Funktionen zu.

Intelligente Funktionen wie BoatMonitoring, eLogbook und eServicebuch ermöglichen es Ihnen, ein automatisches Logbuch zu führen, alle Wartungstermine im Blick zu behalten und Ihre Yacht lückenlos zu überwachen.

Everyone is talking about the digital future. But Dehler is implementing it – with the first cloud-based telematics system for series production sailing yachts. You can access your boat's technical data and functions live via the mobile app or via the owner's area at [www.dehler.com](http://www.dehler.com)

Intelligent functions such as BoatMonitoring, eLogbook and eServicebook enable you to keep an automatic logbook, stay on top of all servicing dates and monitor your yacht seamlessly.

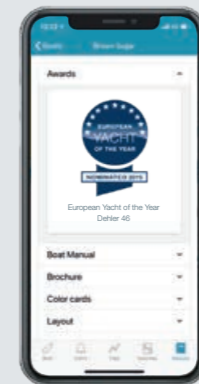

### MANUALS

All manuals and instructions within one app.

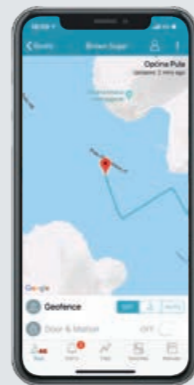

### POSITION

Track your position in real time.

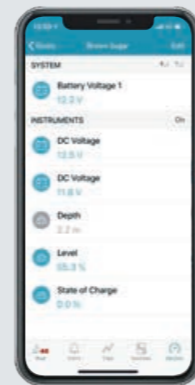

### SENSORS

Monitor your charge levels and devices.

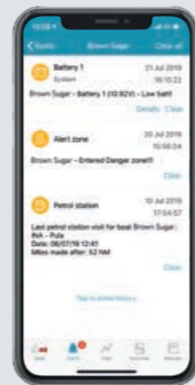

### ALARMS

Push notifications on current events.

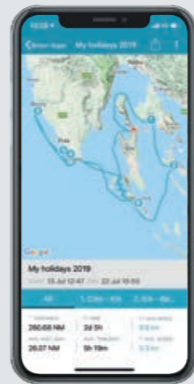

### TRIP LOG

Share your cruises and track data with friends.

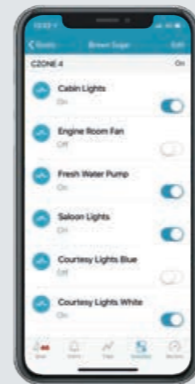

### CONTROL

Operate your electronic devices by remote control.



### LIVE REPORT

Direct contact to your dealer for quick help.



\*Control and sensors depend on the configuration of your Dehler.

# Dehler 46

OPTIONS

# AS YOU LIKE IT

Mit den folgenden Ausstattungsoptionen können Sie genau definieren, wie komfortabel bzw. wie sportlich Ihre Dehler 46 sein soll. Um Ihnen die Wahl ein bisschen zu erleichtern, bieten wir Ihnen einige Extras in besonders attraktiven Paketen an.

The following furnishing options allow you to define precisely how comfortable or sporty your Dehler 46 should be. To make your choice a little easier, we offer some extras, conveniently bundled in packages.

PACKAGES

## COMPETITION – PERFORMANCE UPGRADE



RACE PLUS  
6  
WINCHES



PACKAGES

## NAVIGATION – COMPETITION UPGRADE



PACKAGES

## ENTERTAINMENT – TV PAKET & UPGRADE

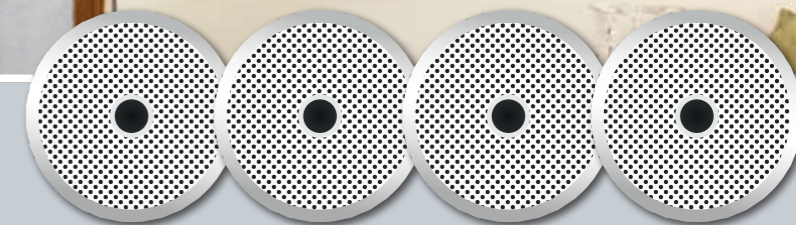



Dehler Maindrop system with lazy bags, available in different colours.



Side deck and bottom anti-slip in White Grey RAL 7047.



Sunbed upholstery on coach roof, available in different colours.



Halyard bags.



Carbon mast, spreaders & boom, rod rigging, backstay tensioner.

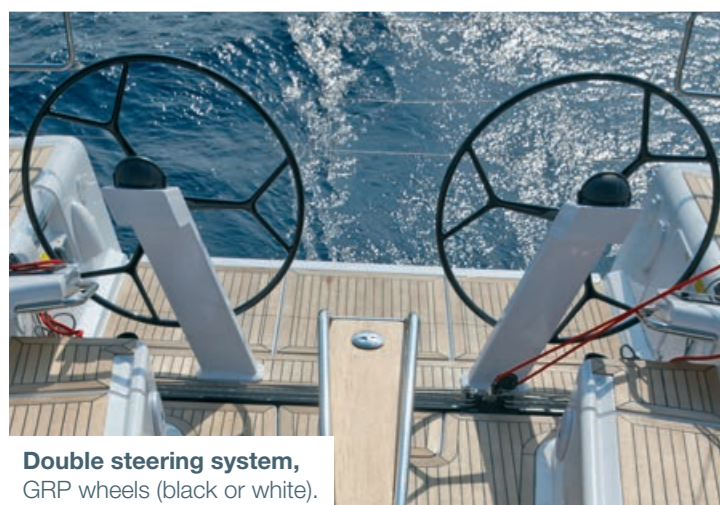

Double steering system, GRP wheels (black or white).

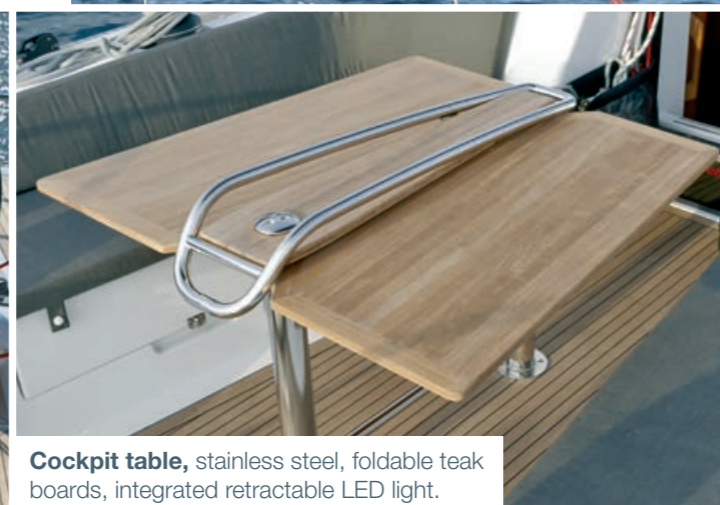

Cockpit table, stainless steel, foldable teak boards, integrated retractable LED light.

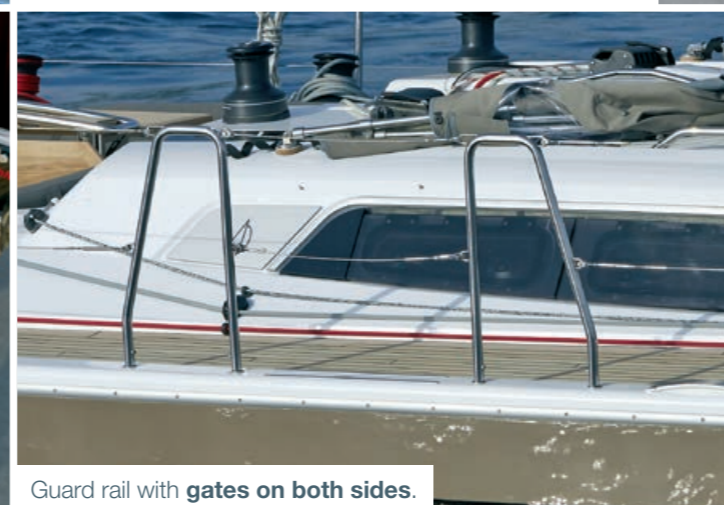

Guard rail with gates on both sides.



Cockpit upholstery, available in different colours.



Microwave in the galley.



Covers for wheels, available in different colours.



Teak or synthetic teak on side deck.



2 halyard winches LEWMAR 50 Race, stb winch electrical.

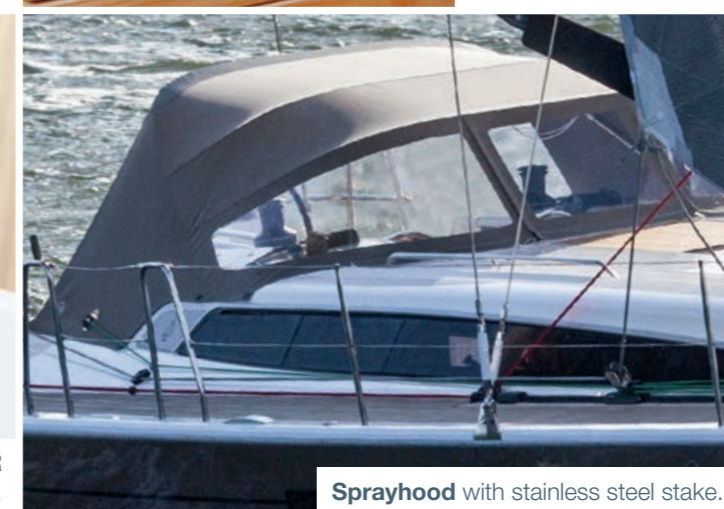

Sprayhood with stainless steel stake.



Retractable bow thruster.







**Dehler**

**Ladebower Chaussee 11**

**17493 Greifswald**

**[www.dehler.com](http://www.dehler.com)**

Design: [www.smz.de](http://www.smz.de) | Print: Eggert Druckerei & Verlag GmbH | Photos: Nico Krauss, Henry Dramsch, Anja Schmidt. This brochure is not contractual. The yachts depicted partly comprise special equipment not included in the standard scope of supply. Illustrations may not correspond with current versions. Subject to alterations in design and equipment without notice and errors excepted.